

A DESIGN AND DEVELOPMENT AS A SYSTEM FOR MACHINE-TO-MACHINE (M2M) WORKING UNDER VISION *MOTIVATED BY THE INTERNET OF THINGS (IOT)*

Scholar Name Om Prakash Yadav Having Enrollment No: SSSCSE1515 under the faculty of PhD CSE SSSUTMS -Sehore, MP. Academic Session 2016-17. Working under the supervision of R.P Singh

ABSTRACT

Machine-to-machine (M2M) communication is turning into an undeniably essential piece of mobile activity and in this way additionally a subject of real enthusiasm for mobile communication research and telecommunication institutionalization bodies. M2M communication offers different universal administrations and is one of the primary empowering agents of the vision motivated by the Internet of Things (IoT). The idea of mobile M2M communication has developed because of the wide range, scope provisioning, high reliability, and diminishing expenses of future mobile networks. By the by, M2M communications posture noteworthy difficulties to mobile networks, e.g., because of the normal extensive number of gadgets with synchronous access for sending little measured information, and a various application range. Machine to Machine (M2M) can be portrayed as technologies which permit both wired and remote frameworks to speak with different gadgets of the same ability. M2M conveys a few advantages to industry and business, since it can be utilized as a part of an extensive variety of applications for observing and control purposes. It is normal that M2M technologies when joined with advanced mobile phones will end up plainly necessary components in savvy homes. As needs be, in this investigation, a specimen application of M2M technologies is displayed. In the introduced application, utilizing temperature information gave by sensors; the savvy ventilation system consequently modifies itself. In spite of the fact that the displayed application is only a basic case of how M2M can be utilized, it has the capability of influencing all ranges enhancing our everyday life. Moreover, an extensive review is given to M2M benefit prerequisites, significant current institutionalization endeavors, and up and coming M2M-related difficulties.

INTRODUCTION

Machine to machine (M2M) communications empower the trading of information between any sorts of machines and devices. In spite of the fact that M2M communication is commonly utilized for remote observing and control, it empowers imaginative advances in technology and can be utilized for some different purposes in a substantial number of applications including assembling and inventory control, ecological checking and creature tracking, shrewd Energy, associated

homes, keen signage, and in-vehicle frameworks. Essentially, in M2M communications, remote sensors assemble information and send it remotely to a network, where it is next steered, frequently through the Internet, to a server. The product running on the server breaks down the information and follows up on.

A M2M framework comprises of radio frequency identification (RFID), sensors, remote or cellular communications

connections and programming application customized to help a networked gadget decipher information and settle on fitting choices. M2M currently does not have an institutionalized associated gadget stage and numerous M2M frameworks are worked to be either undertaking particular or gadget particular. Notwithstanding, it is normal that merchants should concede to an arrangement of principles for gadget to-gadget communications, as M2M turns out to be more unavoidable.

Lately, M2M has been chosen for some requesting applications, for example, telemetry and Supervisory, Control and Data Acquisition (SCADA). Not quite the same as telemetry, which can be portrayed as programmed remote transmission of measured information, and SCADA, the vast majority of M2M applications depend on settled existing principles as far as communication conventions and transmission strategies. Be that as it may, telemetry applications are for the most part in view of restrictive arrangements created to address particular client or application necessities. Then again, M2M utilize open conventions additionally found on the Internet and neighborhood networks. What's more, the information groups are comparable in appearance.

The communication network in M2M applications is the focal association

segment between the information incorporation point and information end focuses, and can be built up utilizing a neighborhood, remote network, open telephone network/Integrated Services Digital Network (ISDN), the Global System for Mobile Communications (GSM) mobile network, or comparative technologies. Remote M2M associations can be set up finished bigger separations by methods for GSM mobile associations. As appeared in Figure 1, for this situation, a cell phone network gave by a GSM organization frames the physical network and the supplier offers and guarantees access to its cell phone network in light of an authoritative understanding. From an extensive variety of M2M applications, tracking, telemedicine, and framework checking are the most widely recognized ones which have been actualized by means of GSM technologies. It is predicted that M2M applications in view of GSM technologies have incredible potential regarding development and cost sparing. Currently, the absence of institutionalization in interfaces and information designs between information end focuses and the information mix point is as yet the primary issue in GSM based M2M applications.

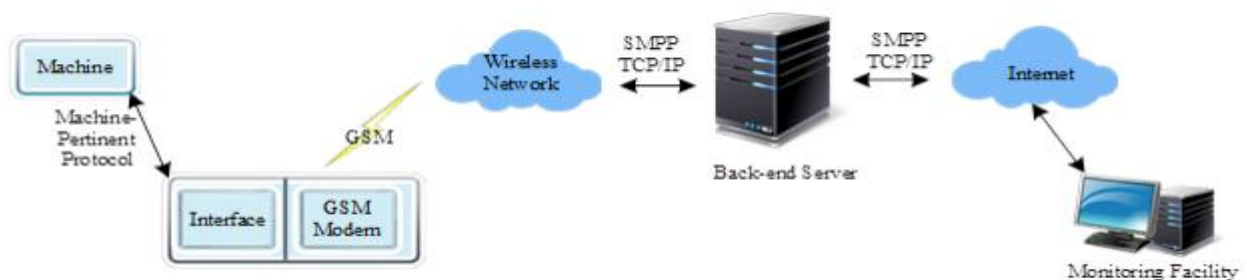

Figure 1 Implementing an M2M application over a GSM network

It is broadly expected that M2M technologies joined with advanced mobile phones will assume a critical part in savvy homes. In this manner, significant device vendors and telecommunications specialist organizations have begun to concentrate on these technologies and put advanced mobile phone applications in their offerings and techniques. In this investigation, we concentrate on building up an illustration M2M application to indicate how M2M technologies can enhance our lives. In spite of the fact that the created application requires the utilization of shrewd air conditioners, it can be designed to work with standard air conditioners with a remote control.

The rest of the paper is composed as takes after. M2M communications, Constrained Application Protocol (COAP) and Session Initiation Protocol (SIP) are evaluated Section 2. Segment 3 exhibits the utilization M2M for shrewd home applications. Area 4 clarifies the plan of a specimen M2M application and presents the acquired outcomes. At long last, the paper is finished up in Section 5.

M2M COMMUNICATIONS AND PROTOCOLS

M2M can be seen as the arrangement of frameworks, networks, procedures and information which interfaces machines with machines for various purposes. Not quite the same as the greater part of alternate technologies, numerous M2M frameworks are intended to help different applications. For example, an associated home condition can bolster numerous applications, for example, energy administration, security, video on request and control of apparatuses. So also, in a

telemetric application, vehicle occasion information is accessed by various applications, for example, route, condition observing and protection. In spite of the fact that M2M has many advantages, M2M communications introduce a special arrangement of specialized difficulties that must be tended to by any associated application. M2M applications must have the capacity to associate over networks that might be problematic, and that regularly have constrained transmission capacity, particularly while interfacing over cellular networks. M2M devices themselves likewise regularly have restricted handling power and a need to limit control utilization. What's more, due to non-institutionalization, designers frequently pick particular M2M modules which accompany their own particular programming improvement units (SDKs) with merchant particular components for device and application administration. Along these lines, designers and OEMs progress toward becoming bolted into the picked equipment, server favored by the merchant and administration system. This points of confinement both adaptability and interoperability

For the most part M2M designs can be separated into two general classes, to be specific hybrid and all-Internet Protocol (IP), since there is nobody estimates fits-all engineering for M2M technology. Unique in relation to the past, now TCP/IP is accessible in humble equipment, on account of minimal effort across the board networking chips and movement to an expanding interoperability with IP communication inside modern networking measures. Then again, hybrid M2M designs include M2M hubs which can't oblige standard networking interfaces.

Hybrid designs commonly oblige inheritance telemetry-sort frameworks and low-end M2M device hubs, which incorporate aloof sensors, low-frequency devices, and one-time utilize devices like sensors for weapons testing and seismic occasions. Since the primary goal of M2M communications is to expand the level of automation in which the frameworks and devices can trade and offer information, in M2M communications, the protocol and information organize are the key issues to guarantee the consistent information and control streams. Consequently, as of late, there have been considerable measures of institutionalization endeavors to build up a conclusion to-end design for M2M communications and accelerate the reception of remote interconnectivity of various M2M parts.

Protocols used in M2M applications

The protocols used in M2M and Internet of Things (IoT) applications were designed to address the requirements of highly resource-constrained devices and M2M and IoT scenarios. For instance, since HyperText Transfer Protocol (HTTP) over TCP is not feasible in M2M and IoT applications, to close the gap between microcontroller-based low-power devices and the Web of Things, COAP was developed and in this way RESTful applications can talk end-to-end to tiny devices using Request-uniform resource identifiers (URIs) for addressing and uniform interfaces for interaction. Similarly, the adoption of SIP for session control ensured interoperability of networks, services, and devices from different providers. Later on, SIP has been adopted as the standard for session control of M2M video applications. In the

following subsections, COAP and SIP protocols are briefly explained.

SIP

Taste is an application-layer control protocol for signaling and controlling multimedia communication sessions. While it is generally utilized as a part of Internet communication applications, it is additionally utilized for texting all finished IP networks. It is a content based protocol with punctuation like that of HTTP and characterizes the messages sent between endpoints to oversee foundation, end and different elements of a call. Since it is an application layer protocol, it is free of the fundamental layers. Like COAP, the institutionalization of SIP has been done by the IETF. There are two unique sorts of SIP messages to be specific solicitations and reactions. While the main line of a reaction message has a reaction code, the principal line of a demand message has a technique to characterize the idea of the demand and a URI, a series of characters used to recognize a name of a resource, to demonstrate where the demand ought to be sent.

COAP

COAP is an application layer protocol intended to be utilized as a part of basic asset constrained hardware devices, for example, low power sensors, switches, valves and comparable segments, and enables them to impart over the Internet for control and remote supervision purposes. Notwithstanding being effectively incorporated with the web technologies, it additionally meets particular prerequisites, for example, straightforwardness, low overhead and multicast bolster, which are critical for

profoundly inserted devices with restricted figuring force, memory and power supply, for example, M2M and IoT devices. The Internet Engineering Task Force (IETF) Constrained Restful conditions Working Group has done the significant institutionalization work for this protocol so as to make the COAP protocol suite be appropriate for M2M and IoT applications by including an arrangement of new functionalities. Since COAP is based over the User Datagram Protocol (UDP), it has essentially low overhead and backings multicast. It is composed into two layers, to be specific, the exchange layer and the demand/reaction layer. While the previous is in charge of taking care of the single message trade between end focuses, the last is in charge of the transmission of solicitations and reactions for the asset control and transmission.

M2M FOR SMART HOMES

These days, the most up to date devices and applications are disentangling our tasks and improving utilization of accessible resources, and changing the way we live. Different home automation answers for energy administration; security, remote observing and control, and e-health offer different focal points and enhance the way we live. As appeared in Figure 2, shrewd home arrangements with the offered arrangements can be viewed as the following phase of existing home automation arrangements. Despite the fact that the rundown of keen home

applications is open-finished, home look after the elderly and crippled, energy proficiency, comfort and excitement, and health and security are the real application regions of shrewd home administrations.

Shrewd homes are intricate heterogeneous situations involving three principle parts, to be specific a home automation framework, a control framework, and a home automation network. The home automation framework contains an arrangement of home apparatuses which satisfy a few capacities in the house for the prosperity of the mortgage holders. The capacity of the home apparatuses can be generally separated into sensors, actuators or both. The control framework joins human with programming based control by utilizing the data gave by the sensors and the directions sent to actuators and along these lines it accomplishes at least one abnormal state objectives or elements of the brilliant home, as required by the property holders. At last, the home automation network guarantees that all the brilliant home parts can trade status and control data. Run of the mill to all registering frameworks, the engineering of a savvy home is affected by the computational capacities of the parts which fabricate the brilliant home. While both unified and dispersed kind of keen home architectures can be found, with the advances in unavoidable and pervasive registering, conveyed savvy home applications these days are more typical.

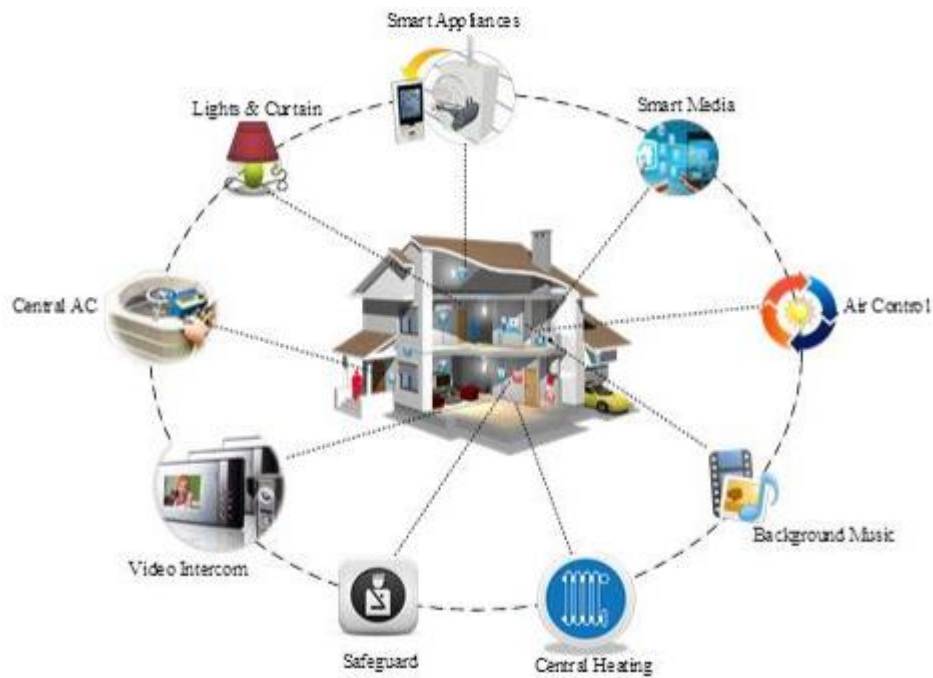

Figure 2 A smart home examples

PROPOSED APPLICATION

To demonstrate the utilization and focal points of brilliant home applications, we outlined a keen air molding application for shrewd home administrations. In the proposed application, the shrewd air conditioner intermittently gets the estimation

of current temperature and showcases it. To do this, the software application running on the savvy air conditioner checks like clockwork to learn whether another esteem has been gotten or not. The logging office of the software application logs all the got values and changes the air conditioner relying upon the got esteem.

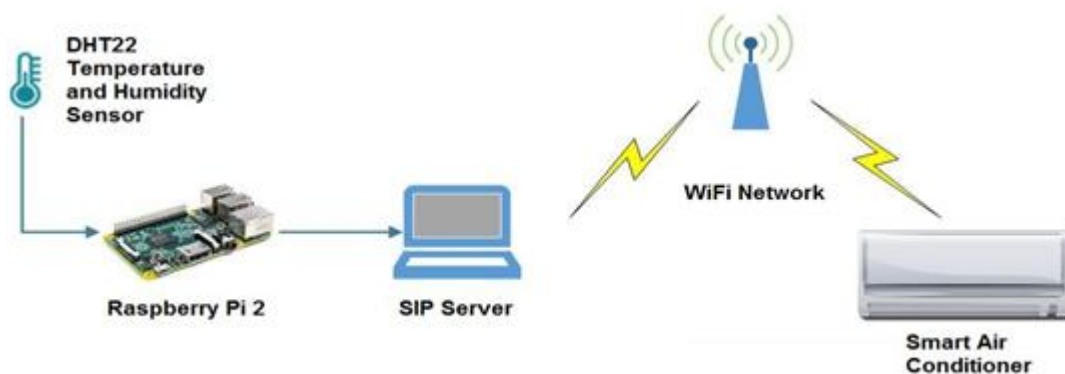

Figure 3 Proposed M2M applications

As appeared in Figure 3, the proposed application comprises of three primary

segments: a SIP server, a Raspberry Pi 2 board with temperature and dampness

sensors [18] and a shrewd air conditioner. As appeared in Figure 4, the SIP server is in charge of giving the association between the keen air conditioner and the

Raspberry Pi 2 board. It isn't occupied all the time since it doesn't deal with the association ceaselessly.

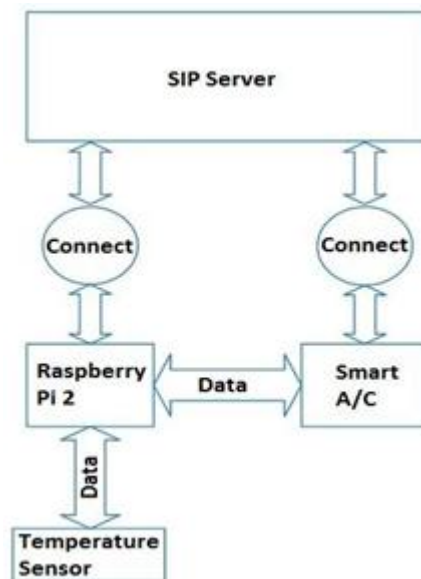

Figure 4 System data diagram

The client can switch on/off and can see the current temperature esteem showed by the brilliant air conditioner. The client can likewise empower the Raspberry Pi 2 board and along these lines the board can get the temperature esteems from the temperature sensor as appeared in Figure 5 and send them to the SIP server. The SIP server goes about as an entryway between alternate devices and can begin the association between them, as appeared in

Figure 6. The client can likewise check every one of the logs made by the framework on the web or disconnected. In spite of the fact that the composed application isn't an extensive one, it is an ideal case to demonstrate one of the many advantages of savvy home applications. Since the outlined application isn't computationally concentrated, it can be executed in ease frameworks.

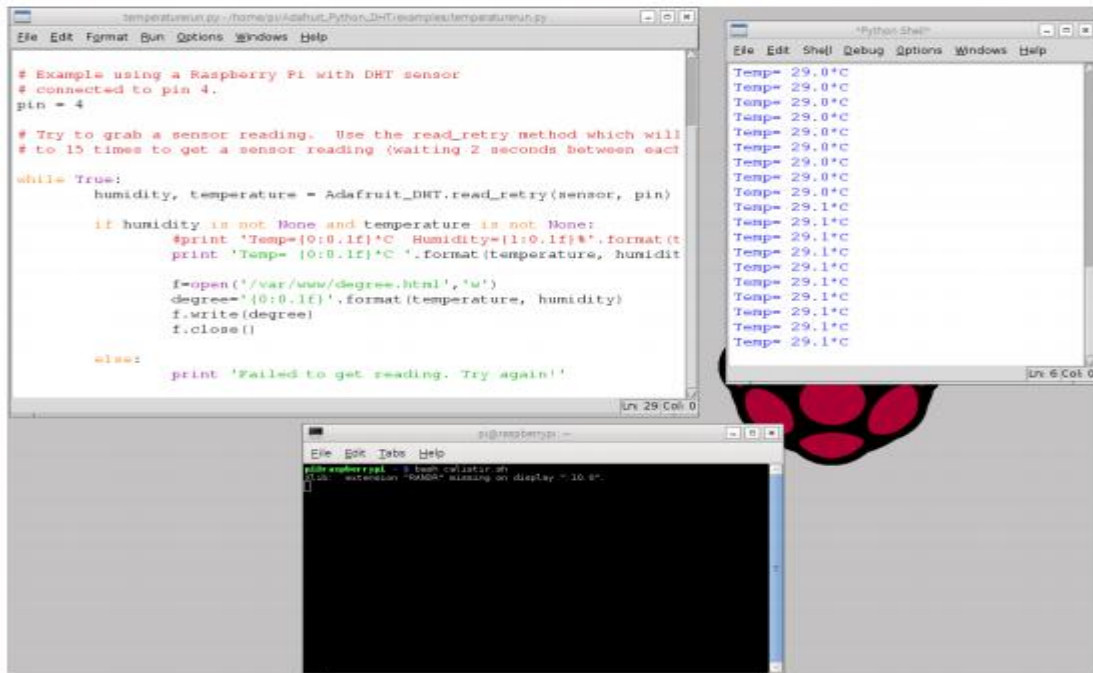

Figure 5 Obtaining temperature values through the Raspberry Pi 2 boards

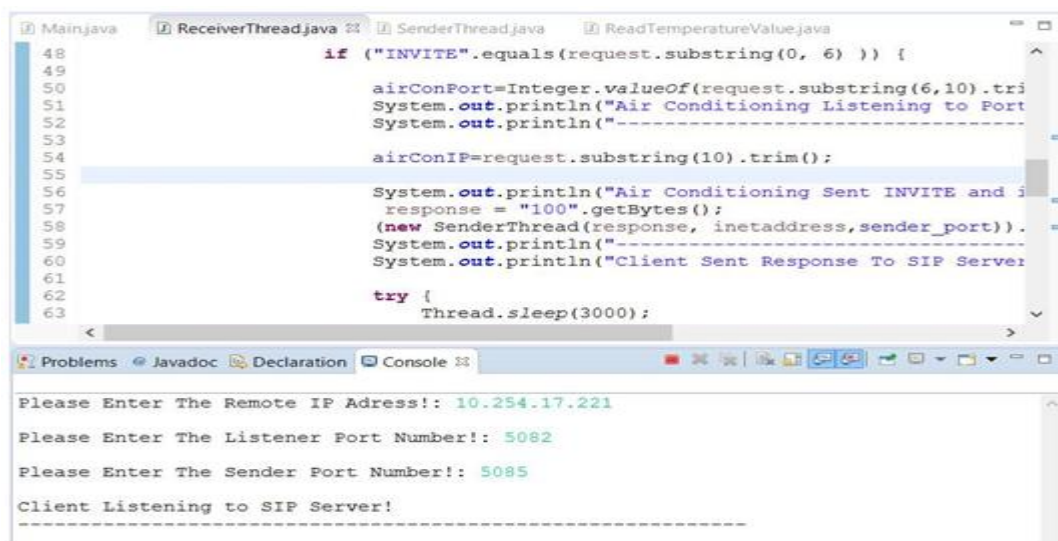

Figure 6 activating the remote device

CONCLUSION

Machine to machine (M2M) communications empower networked devices and administrations to trade data and perform at least one activity without the manual help of people. M2M communication can be utilized for

Different purposes in an extensive variety of applications, and henceforth can convey a few advantages to industry and business. They are seen as a key empowering influence of the Internet of Things (IoT) and pervasive applications, similar to mobile healthcare, telemetry, or shrewd transport frameworks.

In this paper, we display M2M communication based control of an air conditioner to demonstrate the convenience and down to earth execution of M2M. Utilizing temperature esteems gave by a gathering of sensors, the air conditioner consequently alters itself. This application is a basic case of how M2M technologies have begun to enhance our day to day life. Source code of the application is accessible upon ask for by the perusers. As a future work, we intend to coordinate different functionalities and administrations to the proposed application, and join it with other keen home applications.

REFERENCES

1. Wu, G., Talwar, S., Johnsson, K., Himayat, N. and Johnson K. D. 2011. M2M: From mobile to embedded internet. *IEEE Communications Magazine*, 49(4), 36-43.
2. Höller, J., Tsiatsis, V., Mulligan, C., Karnouskos, S., Avesand, S. and Boyle, D. 2014. *From Machine-to-Machine to the Internet of Things: Introduction to a New Age of Intelligence (Elsevier)*
3. Chen, K.-C. and Lien, S.-Y. 2014. Machine-to-machine communications: Technologies and challenges. *Ad Hoc Networks*, 18, 3-23.
4. Niyato, D., Xiao, L. and Wang, P. 2011. Machine-to-Machine communications for home energy management system in smart grid. *IEEE Communications Magazine*, 49(4), 53-59.
5. Severi, S., Sottile, F., Abreu G., Pastrone, C., Spirito, M. and Berens, F. 2014. M2M technologies: Enablers for a pervasive Internet of Things. *2014 European Conference on Networks and Communications (EuCNC)*, 1-5.
6. Martsola, M., Kiravuo, T. and Lindqvist, J. K. O. 2005. Machine to machine communication in cellular networks. *2nd International Conference on Mobile Technology, Applications and Systems*
7. Biral, A., Centenaro, M., Zanella, A., Vangelista, L. and Zorzi, M. 2015. The challenges of M2M massive access in wireless cellular networks. *Digital Communications and Networks*, 1(1), 1-19.
8. Bruns, R., Dunkel, J., Masbruch, H. and Stipkovic, S. 2015. Intelligent M2M: Complex event processing for machine-to-machine communication. *Expert Systems with Applications*, 42(3), 1235-1246.
9. Al-Karaki, J. N., Chen, K.-C., Morabito, G. and de Oliveira, J. 2014. From M2M communications to the Internet of Things: Opportunities and challenges. *Ad Hoc Networks*, 18, 1-2. ITU-T. 2013. *Machine-to-Machine Applications*. [ONLINE] Available at: <http://www.itu.int/en/ITU-T/focusgroups/m2m/Pages/default.aspx>. [Accessed 8 June 2015]
10. Shelby, Z., Hartke, K. and Bormann, C. 2013. *Constrained Application Protocol (CoAP), IETF Internet-Draft, draft-ietf-core-coap-18*. [ONLINE] Available at:

<http://tools.ietf.org/id/draft-ietf-core-coap>. [Accessed 8 June 2015].

11. Bormann, C., Castellani, A. P. and Shelby, Z. 2012.CoAP: An Application Protocol for Billions of Tiny Internet Nodes. *IEEE Internet Computing*, 16(2), 62-67.
12. Rosenberg, J., Schulzrinne, H., Camarillo, G., Johnston, A., Peterson, J., Sparks, R., Handley, M. and Schooler, E. 2002.*Sip: Session Initiation protocol*, Network Working Group. [ONLINE] Available at: <http://tools.ietf.org/html/rfc3261> RFC2543. [ONLINE] Available at: <https://www.ietf.org/rfc/rfc2543.txt>. [Accessed 8 June 2015].
13. Badica, C., Brezovan, M., and Badica, A., "An Overview of Smart Home Environments: Architectures, Technologies and Applications," Proceedings of BCI'13, September 19-21, 2013, Thessaloniki, Greece, pp. 78-85.